

HAND FORGED IRON SPEAK EASY UNIT INSTALLATION INSTRUCTIONS

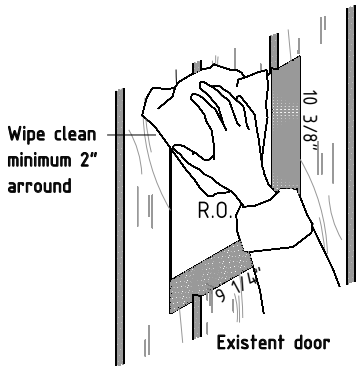

STEP # 1 :

Wipe clean minimum of 2" around cut opening for speak easy grill. (exterior and interior).



STEP # 2 :

Remove brown film from butyl tape attached to "V" groove filler. Then, place groove fillers in each groove, aligned with edge of prepared opening. (Interior and exterior).

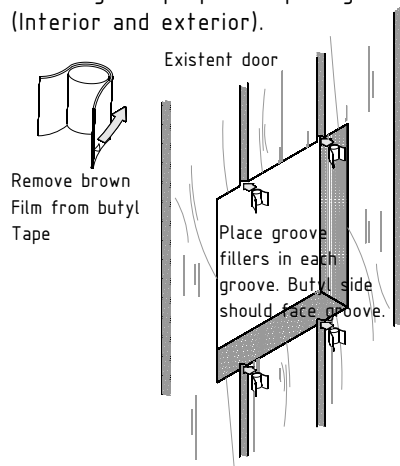

STEP # 3 :

Slowly remove brown film backing from butyl tape on "A" and "B" grill casings. Insure butyl tape remains in place against grill casing.

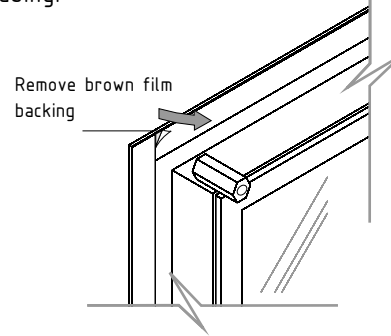



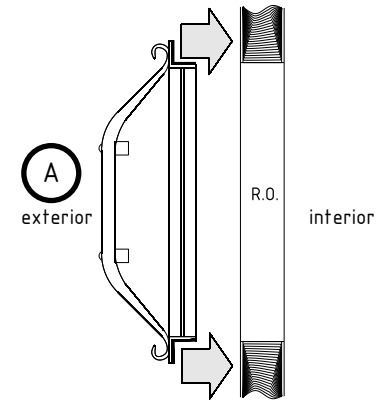

STEP # 4 :

Insert A grill assembly in prepared opening on exterior face of door and hold in place. Insure that bottom of grill rests on bottom of prepared opening.



CROSS SECTION
BILL OF MATERIALS

	SG-TB.01	x 5
	SG-BT	x 48"
	SG-SP.01	x 1
	SG-VGF	x 12

HANDING DIAGRAM

LEFT HAND - MATCH SPEAK EASY HINGE WITH DOOR HINGE

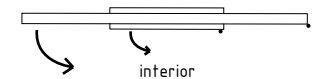

RIGHT HAND - MATCH SPEAK EASY HINGE WITH DOOR HINGE



STEP # 5 :

Carefully peel glaze tape film from glass attached to "A" Grill assembly).

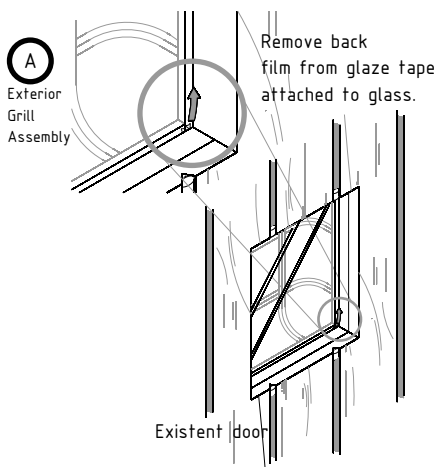

STEP # 6 :

Insert "B" grill assembly in prepared opening on exterior face of door and hold in place. Insure that bottom of grill rests on bottom of prepared opening.

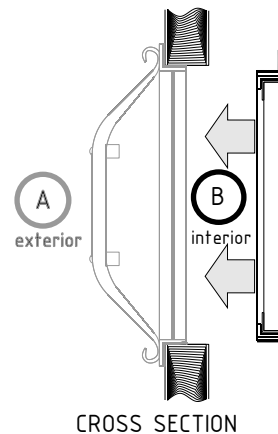

STEP # 7 :

Handtighten bolts from B grill side until secure. Then, tighten with a 7/16" socket wrench. NOTE: To prevent paint coating removal, place masking tape over bolt head and surroundings before tightening. DO NOT OVERTIGHTEN to prevent shearing of bolt.

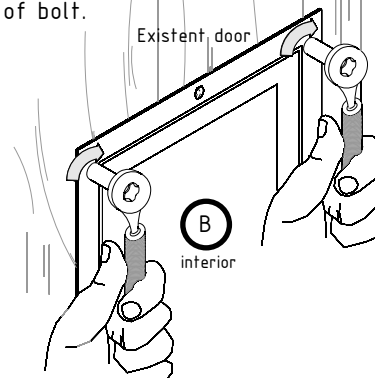

CROSS SECTION